

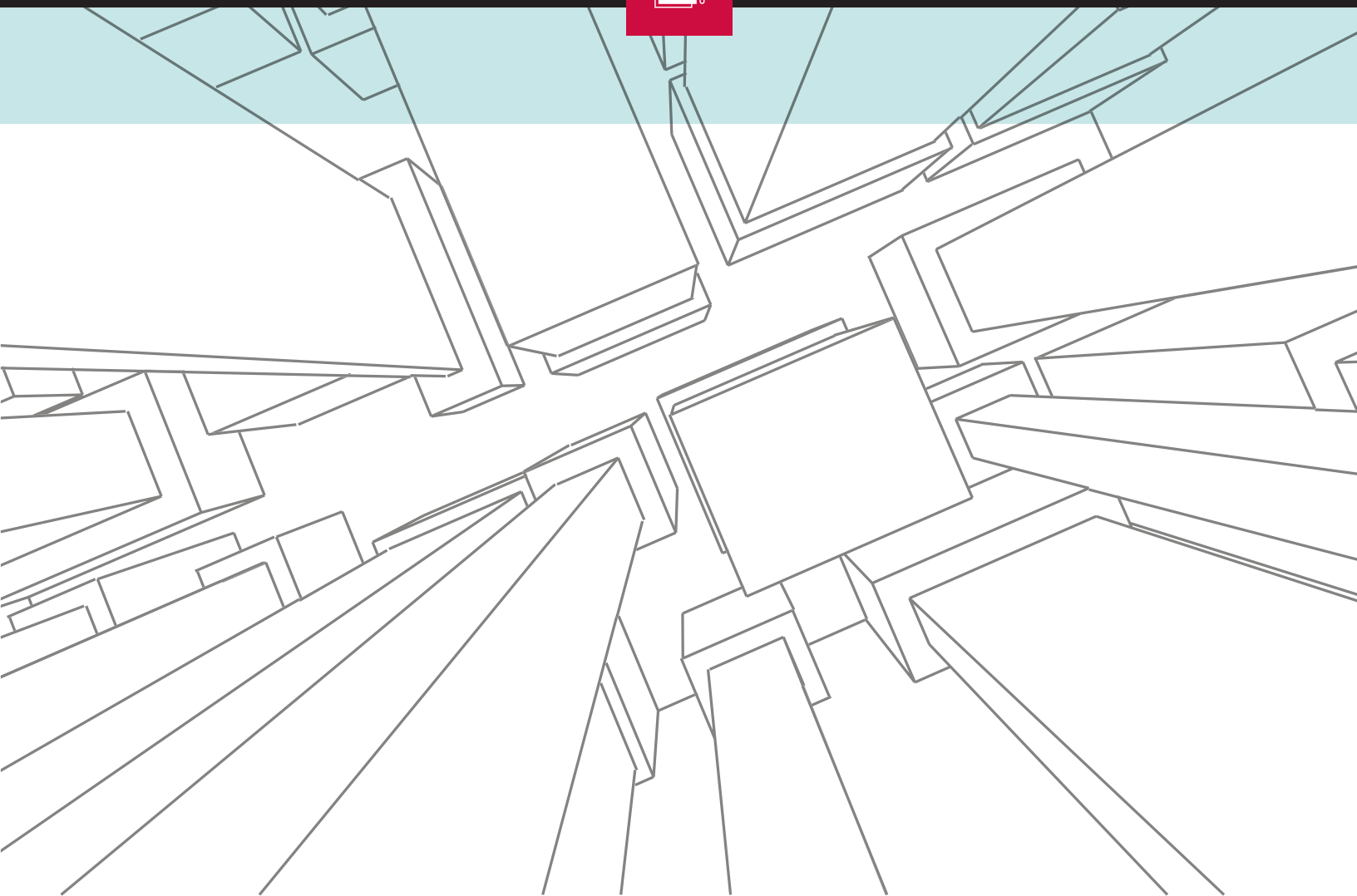

SERENUS LULA

PLANNING GUIDE



 **SERENUS LULA
PLANNING GUIDE**

This planning guide was created to assist builders, architects, contractors and elevator professionals in planning for a LULA elevator to meet the requirements of ASME A17.1/CSA B44 Safety Code for Elevators. It will provide you with nominal dimensions and specifications which are required for the initial planning stages of your project. The following guide is applicable to our Serenus model.

It is important to know and to adhere to all regulations pertaining to the installation and use of elevators to ensure that the product is used correctly and safely. Federal Elevator strongly recommends the following:

- That the proper code authority having jurisdiction in the area where the elevator will be installed be contacted directly,
- That the person responsible for the project is familiar with all legal requirements governing the installation and the use of elevators.

Questions?

Please contact us at **(905)458-4015** or at **sales@federalev.com**. All projects are issued a serial number beginning with F- and followed by four numbers. Please reference this number when communicating with us.



TABLE OF CONTENTS

1	General Specifications	12	Type A
2	Preparatory Work by Others	13	Right 2-Speed Door
4	Standard Laminate Finishes	14	Left 2-Speed Door
5	Warranty	15	Type B
6	Elevator Components	16	2-Speed Door
7	Exploded View	17	Type C
8	Pit Construction	18	2-Speed Door
9	Rail Bracket Detail Roped	19	Type D
10	Rail Forces	20	2-Speed Door
11	Machine Room		



GENERAL SPECIFICATIONS

LULA ELEVATOR	
Load Capacity	1400lbs (635kg)
Rated Speed	30fpm (0.15m/s)
Power Supply	208V/3 Phase /30A or, 600V/3 Phase/15A or 240V/1 Phase/50A.
Drive System	1:2 Roped Hydraulic
Standard Cab Sizes (Other custom sizes available)	36" x 60" (914mm x 1524mm) TYPE C & D ONLY 42" x 60" (1067mm x 1524mm) 51" x 51" (1295mm x 1295mm) 48" x 54"(1219mm x 1372mm)
Maximum Travel	25ft. (7.6m). (This measurement may be exceeded dependant on local codes)
Cab Door	Automatic 2-Speed choice of 36" x 80" or 36" x 84" (3-Speed Optional). Prime Steel ready to accept paint by others, Stainless Steel Optional
Maximum Number of Stops	6 Inline
Cab Height	Choice of 86" & 90" (96" optional)
Pit Depth Required	14" minimum (356mm)
Overhead Clearance	11' 2" minimum (3404mm) Lower Overhead clearance available, please contact us
Control System	Automatic Push Button
Floor Selection	Magnetic Selector
Flooring Material	Plywood (Floor to be finished by customer after elevator is installed)
Control Panel Finish	Stainless Steel (Standard) Brass or Antique Bronze (Optional)
Hall Station Finish	Stainless Steel (standard) – Brass or Antique Bronze (optional)
Motor	4HP (3kW) (5HP [3.7kW] Optional)
Cab Panel Finish Laminate	Choice of – Oyster, Antique White, Fog Grey, Hard Rock Maple, Acajou Mahogany, Select Cherry or Planked Coffee Oak. (See page 3 – for colour samples)
Lighting Supply	120V/15A/60Hz
Standard Features	<ul style="list-style-type: none"> ■ 1 Stainless Steel Handrail ■ Automatic control UL/CSA listed ■ Arrival gongs in cab ■ Direction arrows in cab ■ ADA Phone ■ Auto cab lights ■ Instantaneous safety device ■ Emergency battery lowering ■ Car top Inspection Station ■ Over speed valve ■ Buffers ■ Final Limit Switch ■ Emergency stop and alarm at cab operating panel.



PREPARATORY WORK BY OTHERS

The following lists some of the preparatory work and items to accommodate the elevator that are to be provided by others. While this list is fairly comprehensive, it should be used as a guideline only as there may be other needs that arise out of your specific project.

GENERAL

- Provide a fire rated plumb (+/-1 per 100 ft, +/-25.4mm per 30480mm of travel), square framed and enclosed legal hoistway, including venting, to the size shown on the Federal Elevator drawings.
- Measurements for travel, pit depth and overhead are very critical and must be within ¼" (6mm).
- 14" (356 mm) minimum pit depth.
- A substantial, level pit floor slab to support loads indicated on the Federal Elevator drawings.
- Pit water proofing or sump pump, if required.
- Provide pit light with guard and GFCI duplex receptacle in place marked by our forces.
- 11' 2" (3404mm) minimum overhead. Please contact our office for dimensions less than 11' 2" (3404mm).
- Provide adequate rail bracket support to suit maximum rail bracket spacing of 5' 9" (1750mm) review the floor spacing chart on the Federal Elevator drawings and provide additional supports on all floors as required.
- Guarding and protecting the hoistway during construction shall include panels surrounding each hoistway opening at each floor. A minimum of 47½" (1200mm) high. Hoistway guards to be erected, maintained and removed by others.
- Vertical surfaces of entrance sill supports to be plumb, one above another and square with the hoistway. Finish floor and grout, if required, between door frames to sill line.
- Complete flooring in cab and landings. Maximum 3mm height difference permitted between sill and flooring.
- Permanent lighting at all landings.
- Sliding doors are not meant to be exposed to the elements. A vestibule is required to protect equipment in the hoistway, doors and cab interiors if your design features an external landing.



MACHINE ROOM

- Machine room to meet the requirement of local building and fire codes.
 - Legal access, a self-closing and self-locking door and painted concrete floor.
 - Provide permanent lighting with guards of not less than 200LX at floor level.
 - Provide GFCI duplex receptacle within room.
 - The machine room must have a dedicated HVAC system with a dedicated thermostat to maintain the temperature between 5C and 32C and to ensure that the relative humidity does not exceed 95% within this room.
 - Provide a fused disconnect switch with type 'D' fuses for each elevator including the wiring from the disconnect switch to the power terminals of each controller. Refer to General Layout drawings for permanent power requirements and location of the disconnect switch.
 - Provide a separate fused disconnect switch for the lights for the lift rated at 120V, 15 AMP, including the wiring from the disconnect switch to the light terminals of each controller. Refer to General Layout drawings for permanent power requirements and location of the disconnect switch.
 - Locate the machine room light switch on the inside lock jamb side of the machine room door, along with the elevator and light disconnects where practical.
 - Sleeves/Conduit for electrical wiring and oil lines from machine room to hoistway in a straight run as required. Refer to the Federal Elevator drawings for location of Sleeves/Conduit.
 - Internet connection with modem meeting our requirements to the side of the controller in machine room must be provided. This will be used for video/audio monitoring. Monitoring to be provided by specialized Company.
 - For fire recall:
 1. Smoke detector individual signals from landings, machine room, top of hoistway and general alarm.
 2. N/O dry contacts to be provided in machine room including the wiring to elevator controller.
 3. **IMPORTANT:** full building Fire Alarm Verification needs to be performed by the Fire Alarm Subcontractor in the presence of Federal Elevator mechanic. This must be done at least 2 weeks prior to requesting TSSA inspection and Federal Elevator needs to have the entrance frames blocked no less than 3 weeks prior to be ready to confirm a suitable date for the Fire Alarm Verification.
 - Main Disconnect Switch: 50Amp, 3 pole cartridge fuse type disconnect switch with an elevator rated auxiliary contact and type D fuses. (fuse size on drawings)
 - Cab Lighting: 30Amp, 1 Pole plug fuse type disconnect switch with 15A type D plug fuse (buss T15 or equal)
- **NOTE: Entrance walls to be enclosed after elevator is installed. Reference page 3 of the Federal Elevator drawings for rough opening height of entrances.**



STANDARD LAMINATE FINISHES

Choose from one of the following*:

Cherry



Maple



Planked Coffee Oak



Mahogany

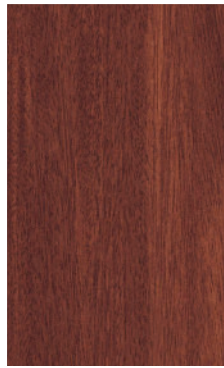

Fog



Oyster

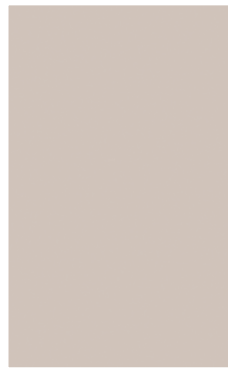

Antique White

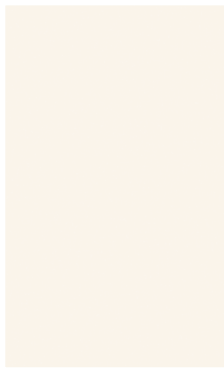

* Please be advised that these colours may be subject to change. Other cab wall options are available, please speak to a Federal Elevator representative.



WARRANTY

For Direct Customers, the warranty will commence when the elevator is turned over for the public's use. For Dealer customers, the warranty starts on the date when the elevator was shipped from the Federal Elevator plant. Please refer to your signed contract to confirm the length of time your unit will be covered. We will make good and/or replace, if necessary, any and all defects due to imperfect workmanship which may appear during the warranty period. These defects, and the repairs required, will be solely determined by Federal Elevator upon receiving at its place of business the piece deemed to be defective by the owner.

This warranty does not cover damages caused by normal wear and tear, accident, fire, unauthorized alterations, vandalism, wilful damage, negligence, acts of God, or other like causes. This warranty shall be considered null and void unless the elevator is maintained properly and consistently by a registered elevator mechanic in the province/state where the elevator is located. Such maintenance shall be performed in accordance with Federal Elevator's recommendations and the requirements of the province's acts and regulations.

■ **NOTE: Units purchased through one of our recognized Dealers will have the same terms as stated in the above warranty but with a time period of one (1) year ONLY. Customer may arrange for a longer warranty period however, this MUST be done prior to the unit being shipped from the Federal Elevator plant.**



ELEVATOR COMPONENTS

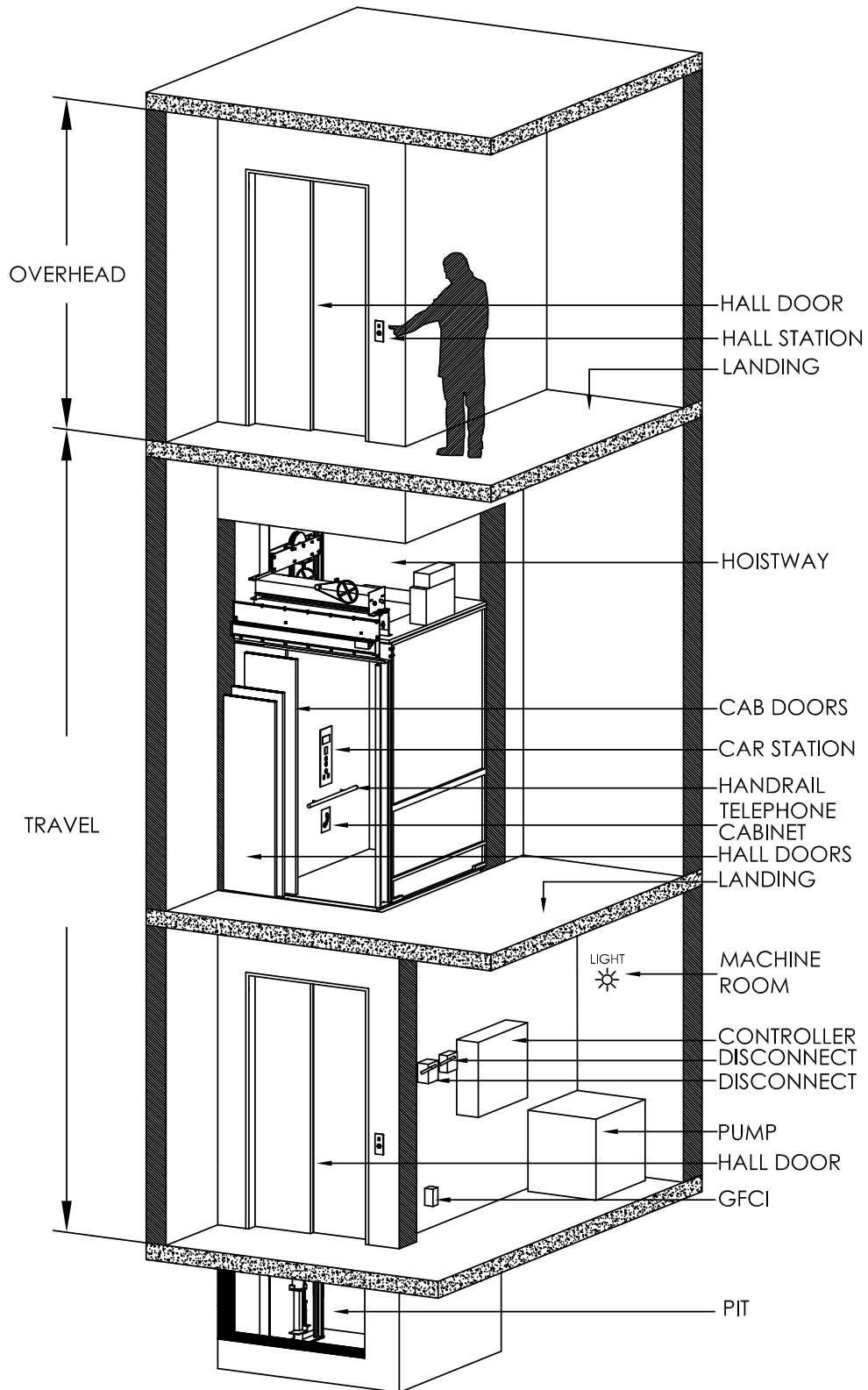



EXPLODED VIEW

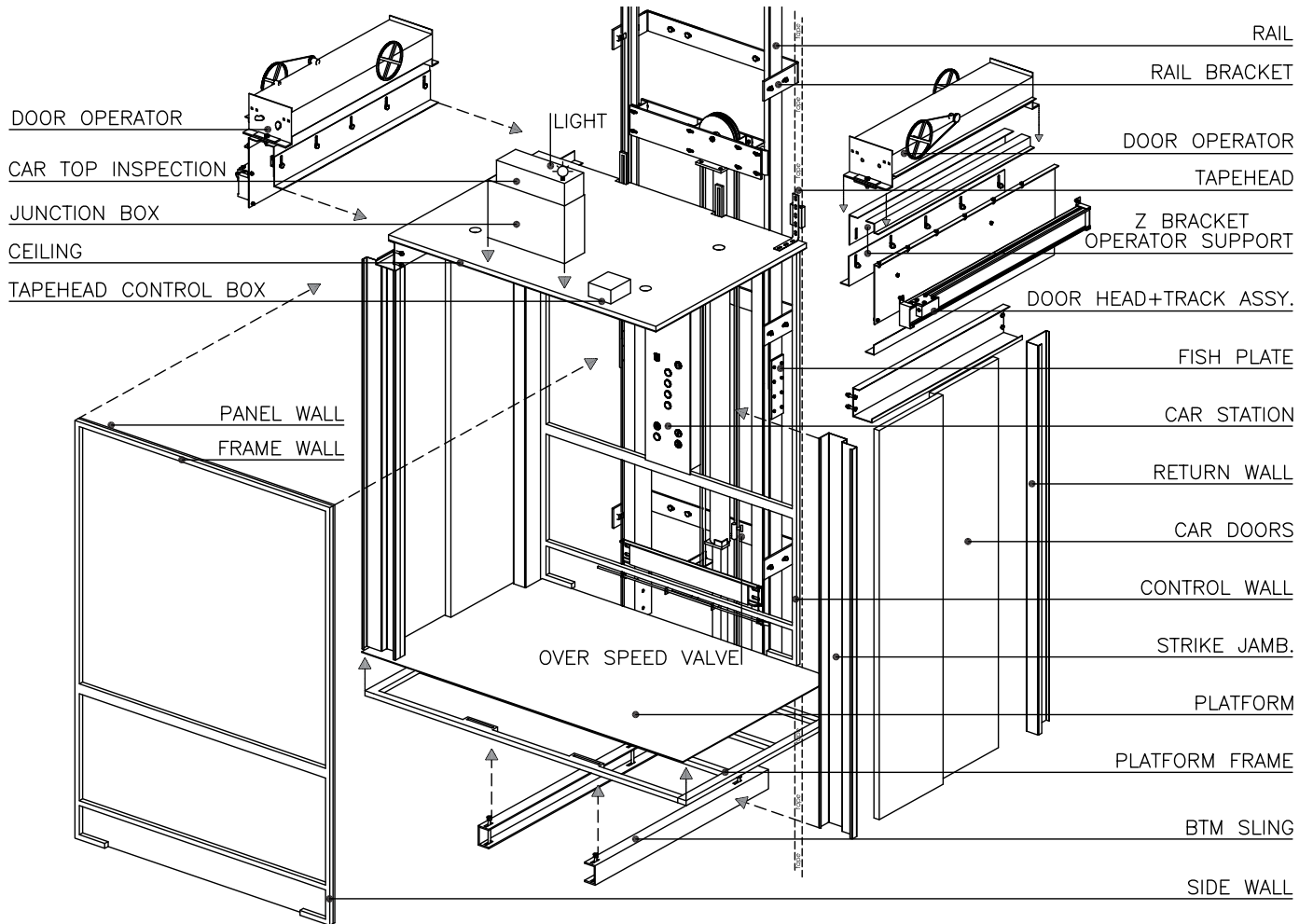



PIT CONSTRUCTION

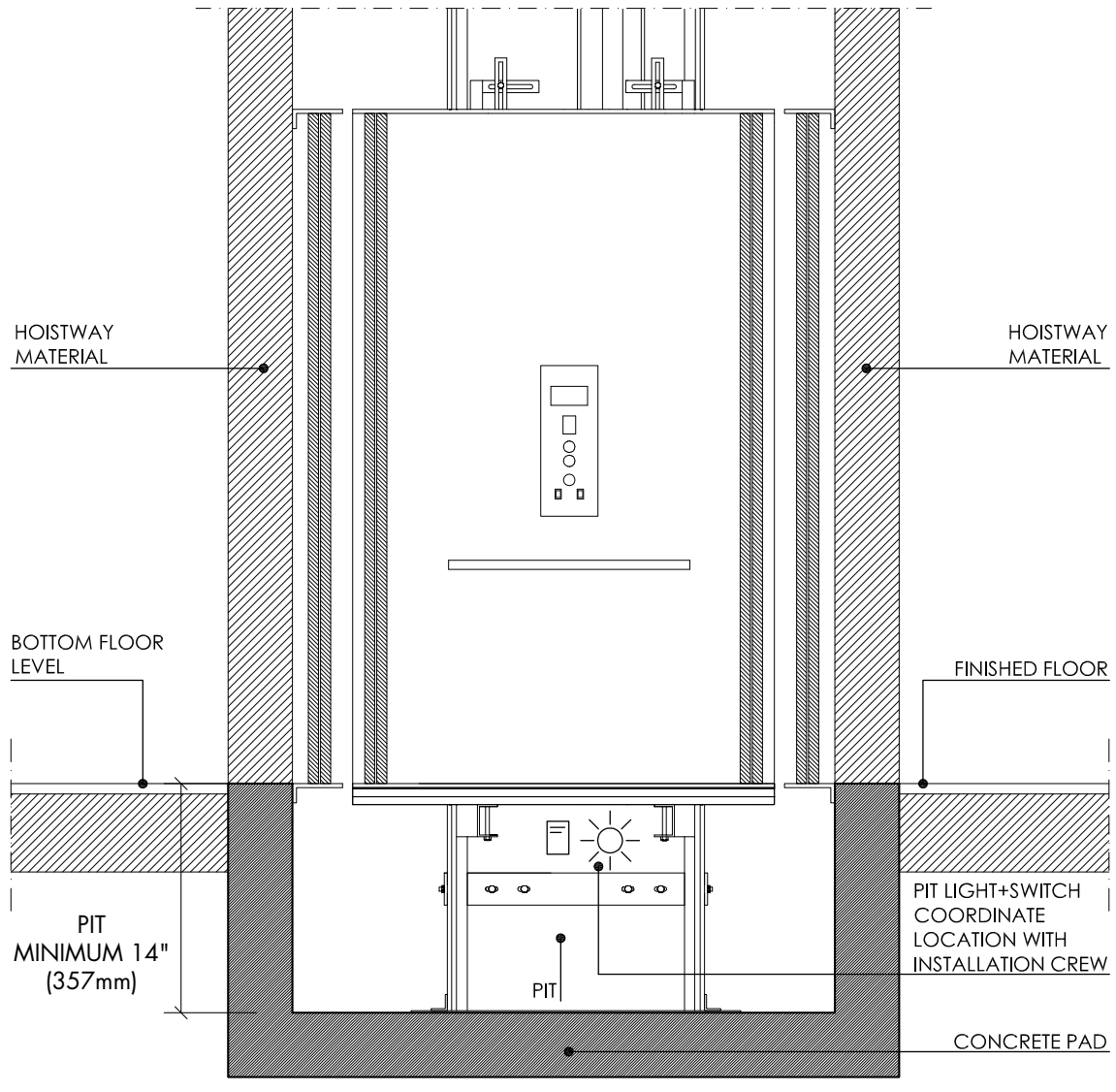

NOTES:

- 1 PIT FLOOR TO SUPPORT LOAD OF 17.0kN OR 3800 lbs (DOUBLED FOR IMPACT).
- 2 PIT TO BE LEVEL, DRY AND FREE OF DEBRIS.
- 3 PIT MUST BE THE SAME WIDTH AND LENGTH AS THE HOISTWAY.
- 4 PIT MINIMUM 14" (355mm).



RAIL BRACKET DETAIL ROPED

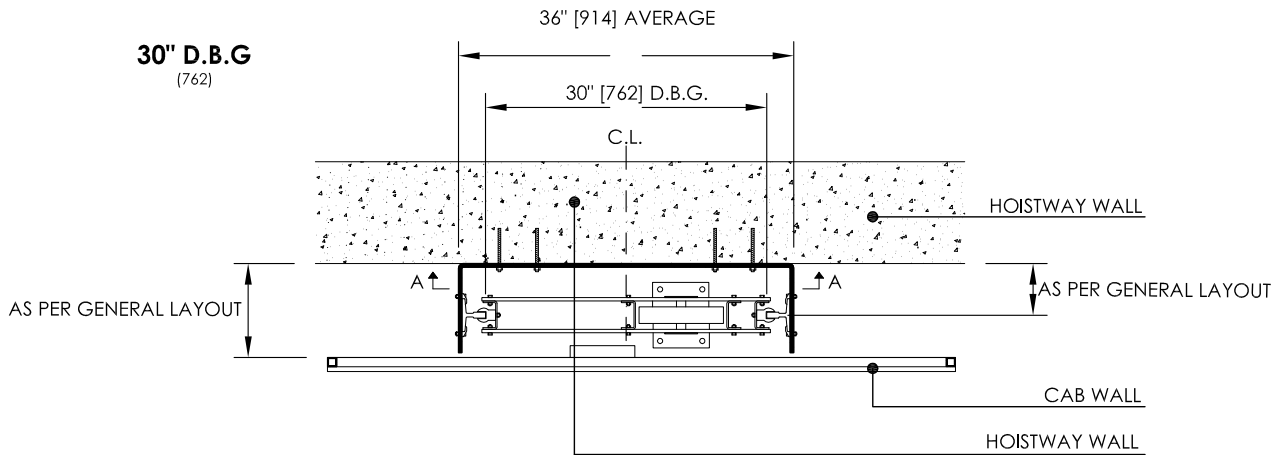

SECTION A-A MOUNTING HOLE LOCATIONS

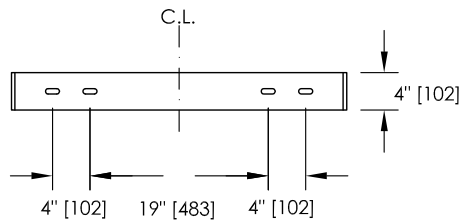

CRITICAL DIMENSIONS SHOWN BELOW ARE CORRECT FOR INSTALLATION PURPOSES:

- 1 WALL TO CENTRE OF CYL. = AS PER GENERAL LAYOUT**
- 2 WALL TO CENTRE OF RAIL = AS PER GENERAL LAYOUT**
- 3 WALL TO CAB = AS PER GENERAL LAYOUT**



RAIL FORCES

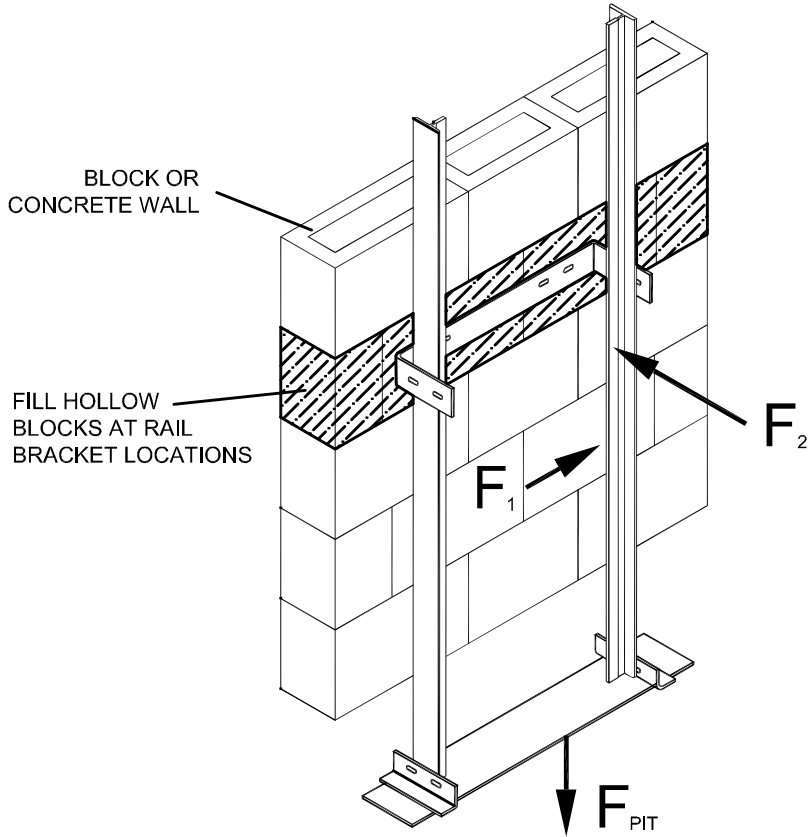

LOAD	DESCRIPTION	LB _f [KN]
F_{PIT}	Load Imposed on Pit Floor (Including Impact)	3825 [17.0]
F_1	Force on Rail	225 [1.0]
F_2	Force on Rail	675 [3.0]



MACHINE ROOM

TYPE 1

2 SLEEVES THROUGH WALL TO HOISTWAY WALL FOR ELECTRICAL AND HYDRAULIC (CONTRACTOR TO PROVIDE)

CONTROLLER
24"Wx9"Dx42"H

PUMP
22"Wx22"Dx26"H

FUSABLE DISCONNECT C/W
AUXILIARY CONTACT
SEE PLANING GUIDE FOR
VOLTAGE REQUIREMENTS

15AMP FUSABLE DISCONNECT
120V, 1PH, 60HZ

GFCI DUPLEX RECEPTACLE

LIGHT SWITCH

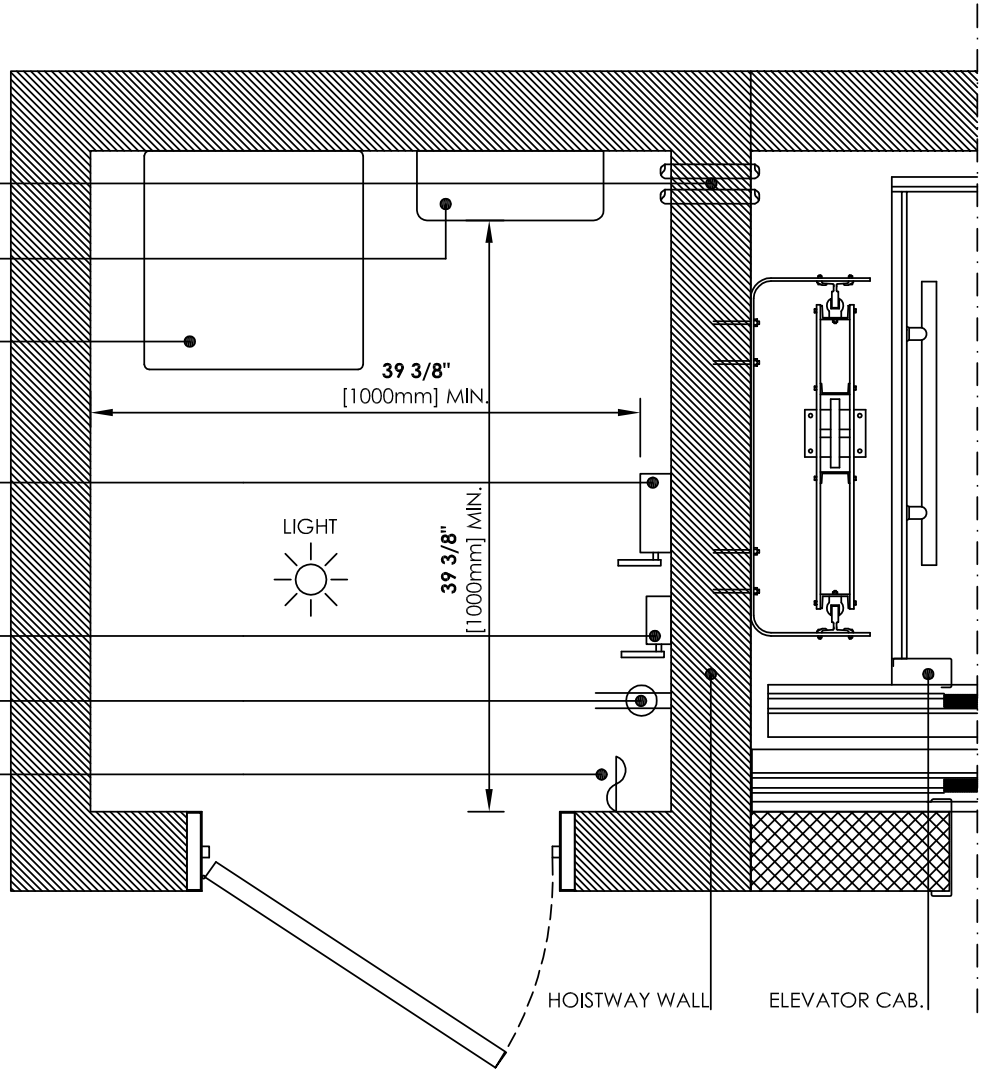

TYPE 2

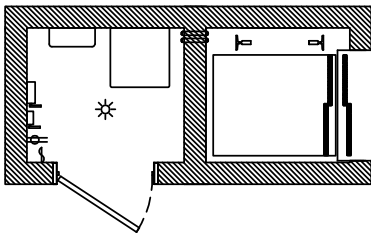

TYPE 3

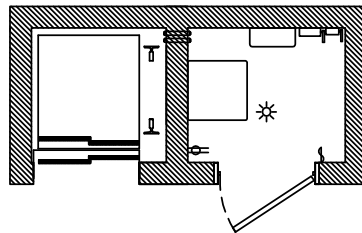

REMOTE

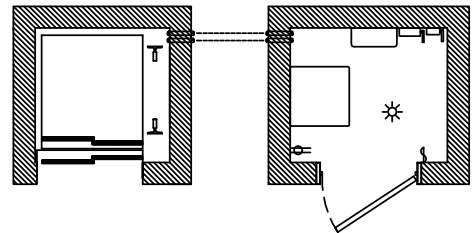



TYPE A

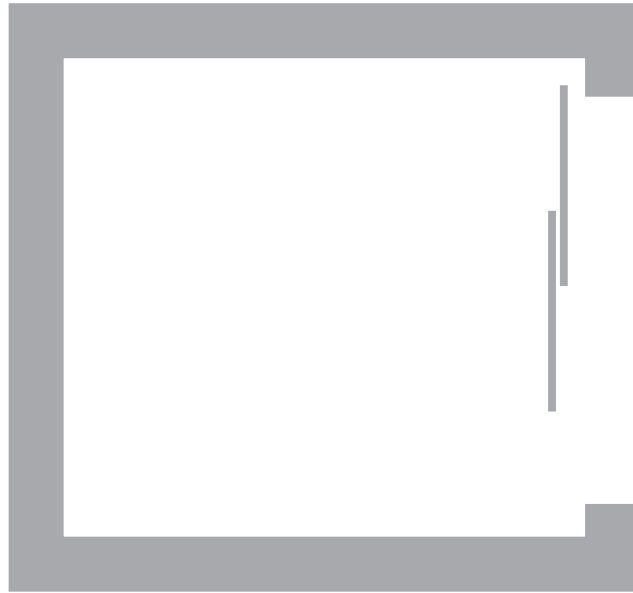

ONE POINT OF ENTRY ON ALL LEVELS

Entrance options:



**2-Speed
Stainless Steel**



**2-Speed
Primed Steel**
Ready to be painted by others
(standard feature)



3-Speed
* Please contact us directly for
dimensions with this door option



TYPE A RIGHT 2-SPEED DOOR

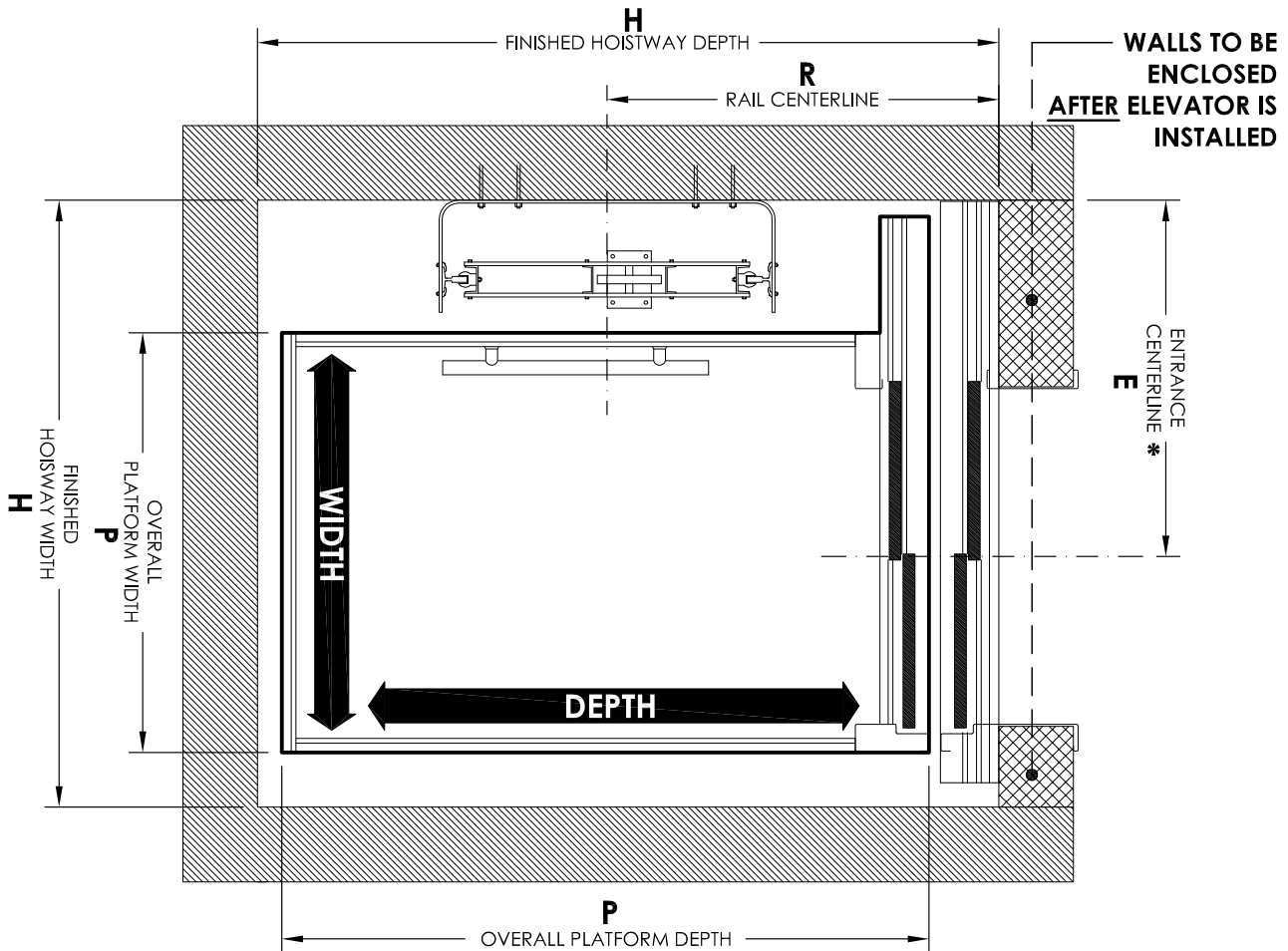

Cab Size (Width X Depth)	42" x 60" 1065mm x 1525mm	48" x 54" 1220mm x 1375mm
Finished Hoistway (H) Width x Depth	68" x 79 1/2" [1730 x 2020]	68" x 74 1/2" [1730 x 1895]
Overall Platform (P) Width x Depth	45" x 69 3/8" [1140 x 1760]	51" x 63 3/8" [1295 x 1610]
Entrance Centerline * (E)	40 3/4" [1035]	40 3/4" [1035]
Rail Centerline (R)	42" [1065]	40" [1016]

*** ENTRANCE CENTRELINE NOTES:**

- FEDERAL ELEVATOR DOES NOT ACCEPT RESPONSIBILITY FOR THESE DIMENSIONS AS THEY WILL VARY DEPENDING ON HOW PLUMB AND STRAIGHT THE HOISTWAY HAS BEEN CONSTRUCTED.
- BARRICADES SHALL BE PROVIDED OUTSIDE EVERY OPENING TO HOISTWAY WHILE ELEVATOR IS BEING INSTALLED. BARRICADES SHALL BE ERECTED, MAINTAINED AND REMOVED BY OTHERS WHEN INSTALLATION WORK IS COMPLETE. THIS IS FOR SAFETY OF OTHER TRADES AND BUILDING OCCUPANTS.
- WALLS TO BE ENCLOSED AFTER ELEVATOR IS INSTALLED.



TYPE A LEFT 2-SPEED DOOR

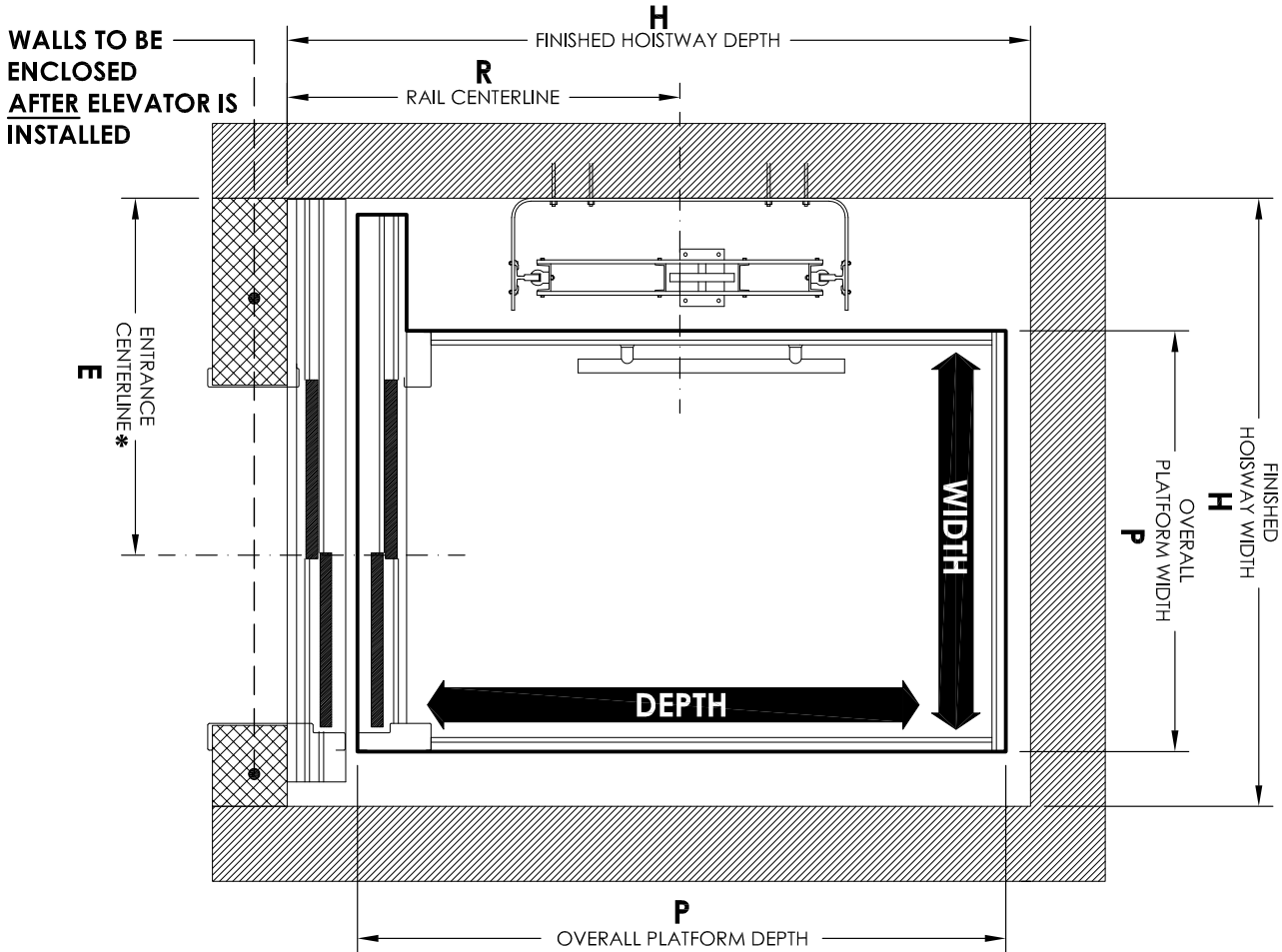

Cab Size (Width X Depth)	42" x 60" 1065mm x 1525mm	48" x 54" 1220mm x 1375mm
Finished Hoistway (H) Width x Depth	68" x 79 1/2" [1730 x 2020]	68" x 74 1/2" [1730 x 1895]
Overall Platform (P) Width x Depth	45" x 69 3/8" [1140 x 1760]	51" x 63 3/8" [1295 x 1610]
Entrance Centerline * (E)	40 3/4" [1035]	40 3/4" [1035]
Rail Centerline (R)	42" [1065]	40" [1016]

*** ENTRANCE CENTRELINE NOTES:**

- FEDERAL ELEVATOR DOES NOT ACCEPT RESPONSIBILITY FOR THESE DIMENSIONS AS THEY WILL VARY DEPENDING ON HOW PLUMB AND STRAIGHT THE HOISTWAY HAS BEEN CONSTRUCTED.
- BARRICADES SHALL BE PROVIDED OUTSIDE EVERY OPENING TO HOISTWAY WHILE ELEVATOR IS BEING INSTALLED. BARRICADES SHALL BE ERECTED, MAINTAINED AND REMOVED BY OTHERS WHEN INSTALLATION WORK IS COMPLETE. THIS IS FOR SAFETY OF OTHER TRADES AND BUILDING OCCUPANTS.
- WALLS TO BE ENCLOSED AFTER ELEVATOR IS INSTALLED.



TYPE B

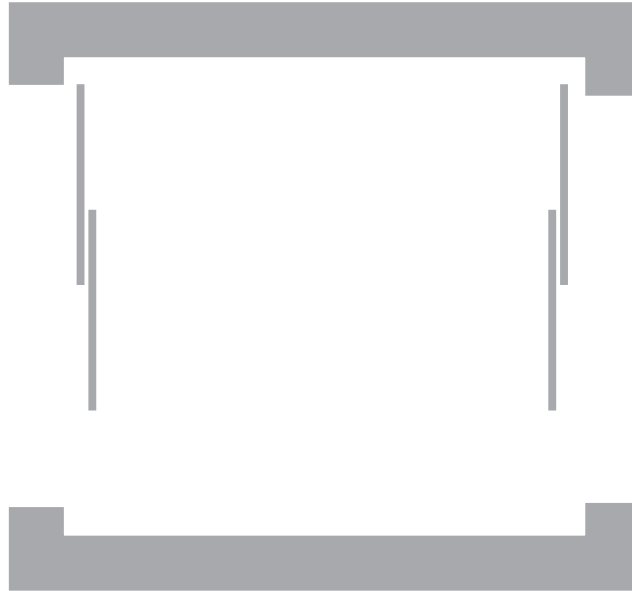

TWO POINTS OF ENTRY ON ALL LEVELS

Entrance options:



**2-Speed
Stainless Steel**



**2-Speed
Primed Steel**
Ready to be painted by others
(standard feature)



3-Speed
* Please contact us directly for
dimensions with this door option



TYPE B 2-SPEED DOOR

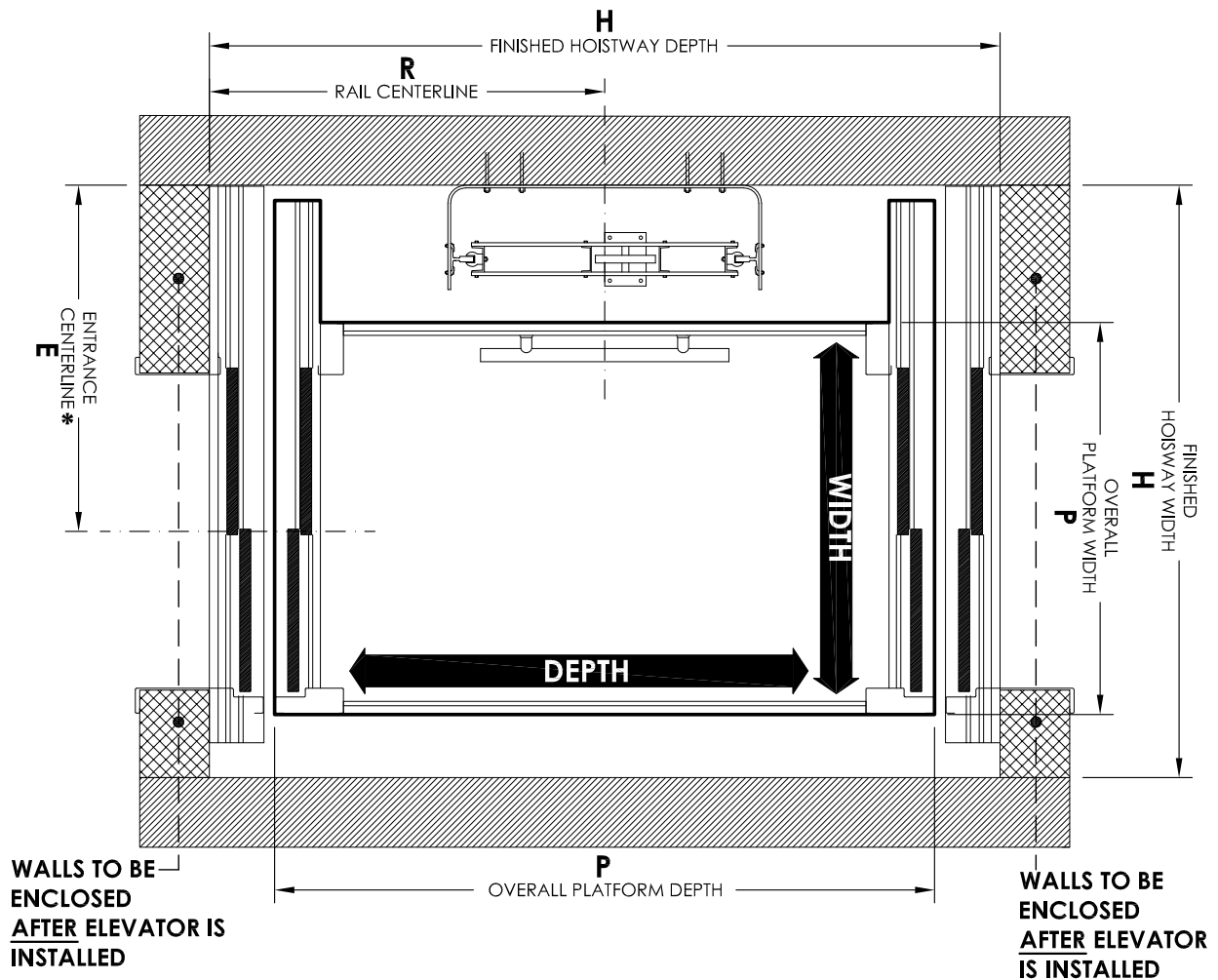

Cab Size (Width X Depth)	42" x 60" 1065mm x 1525mm	48" x 54" 1220mm x 1375mm
Finished Hoistway (H) Width x Depth	68" x 90 3/4" [1730 x 2305]	68" x 84 3/4" [1730 x 2155]
Overall Platform (P) Width x Depth	45" x 75 3/4" [1140 x 1925]	51" x 69 3/4" [1295 x 1770]
Entrance Centerline * (E)	40 3/4" [1035]	40 3/4" [1035]
Rail Centerline (R)	45 3/8" [1155]	42 3/8" [1075]

*** ENTRANCE CENTRELINE NOTES:**

- FEDERAL ELEVATOR DOES NOT ACCEPT RESPONSIBILITY FOR THESE DIMENSIONS AS THEY WILL VARY DEPENDING ON HOW PLUMB AND STRAIGHT THE HOISTWAY HAS BEEN CONSTRUCTED.
- BARRICADES SHALL BE PROVIDED OUTSIDE EVERY OPENING TO HOISTWAY WHILE ELEVATOR IS BEING INSTALLED. BARRICADES SHALL BE ERCTED, MAINTAINED AND REMOVED BY OTHERS WHEN INSTALLATION WORK IS COMPLETE. THIS IS FOR SAFETY OF OTHER TRADES AND BUILDING OCCUPANTS.
- WALLS TO BE ENCLOSED AFTER ELEVATOR IS INSTALLED.



TYPE C

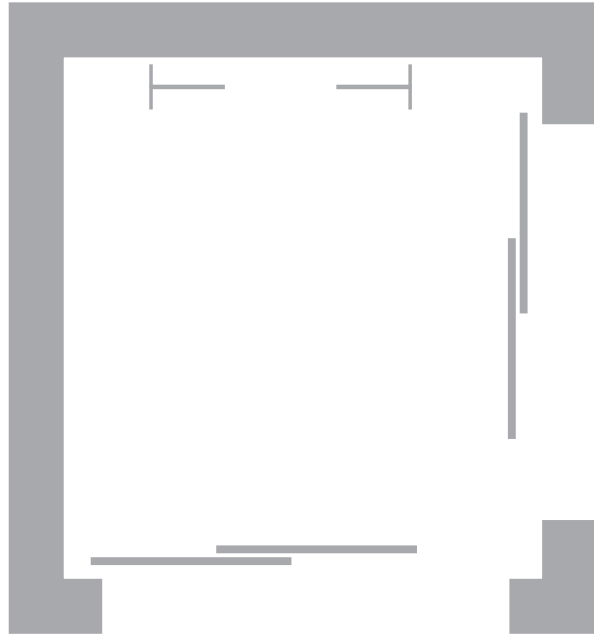

TWO POINTS OF ENTRY ON ALL LEVELS

Entrance options:



**2-Speed
Stainless Steel**



**2-Speed
Primed Steel**
Ready to be painted by others
(standard feature)



3-Speed
* Please contact us directly for
dimensions with this door option



TYPE C 2-SPEED DOOR

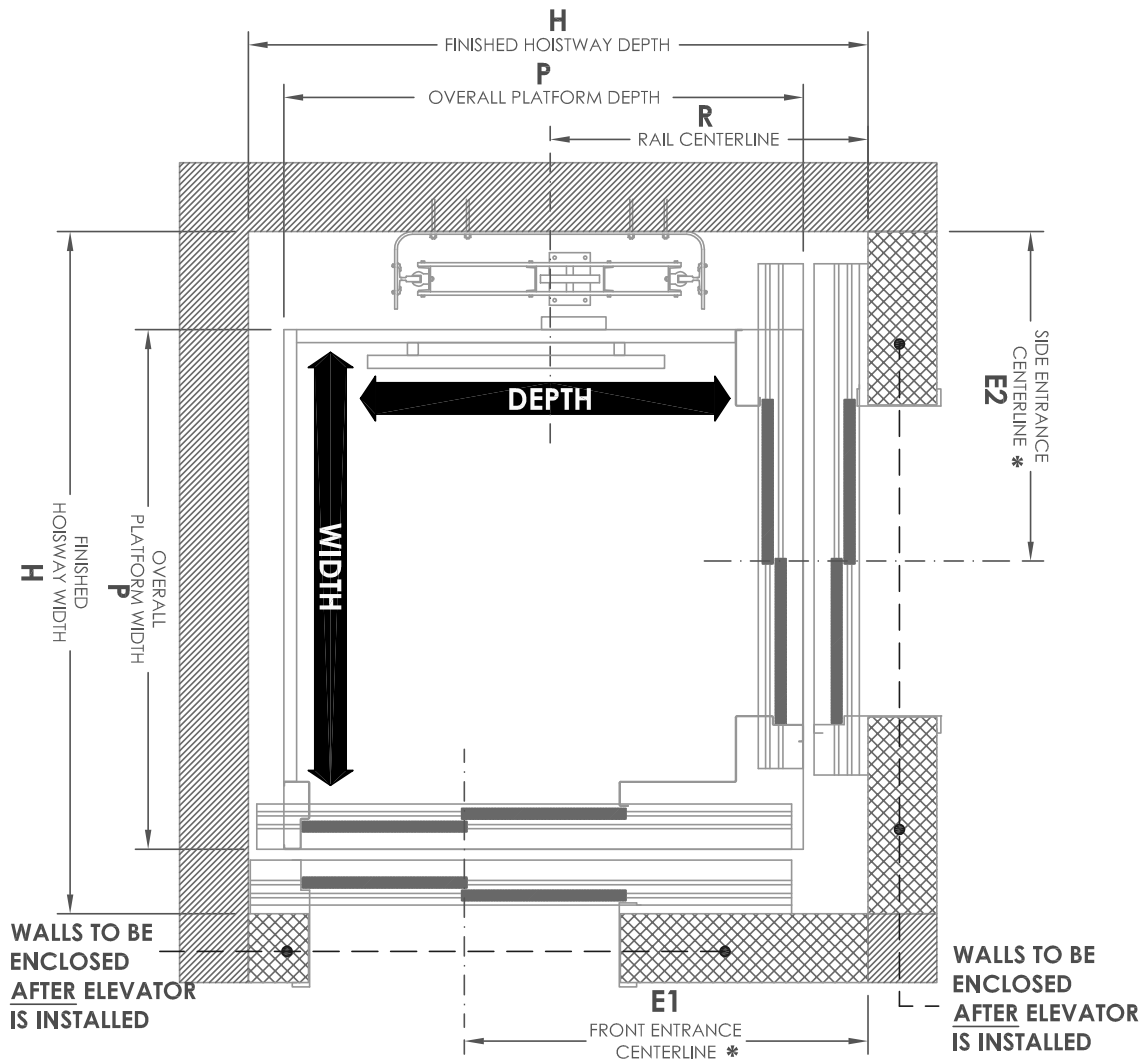

*** ENTRANCE CENTRELINE NOTES:**

- FEDERAL ELEVATOR DOES NOT ACCEPT RESPONSIBILITY FOR THESE DIMENSIONS AS THEY WILL VARY DEPENDING ON HOW PLUMB AND STRAIGHT THE HOISTWAY HAS BEEN CONSTRUCTED.
- BARRICADES SHALL BE PROVIDED OUTSIDE EVERY OPENING TO HOISTWAY WHILE ELEVATOR IS BEING INSTALLED. BARRICADES SHALL BE ERECTED, MAINTAINED AND REMOVED BY OTHERS WHEN INSTALLATION WORK IS COMPLETE. THIS IS FOR SAFETY OF OTHER TRADES AND BUILDING OCCUPANTS.
- WALLS TO BE ENCLOSED AFTER ELEVATOR IS INSTALLED.

Cab Size (Width X Depth)	51" x 51" 1295mm x 1295mm
Finished Hoistway (H) Width x Depth	83" x 72" [2108 x 1829]
Overall Platform (P) Width x Depth	60 3/8" x 60 3/8" [1534 x 1534]
Entrance Centerline * (E)	E1: 46 7/8" [1191] E2: 41 1/4" [1073]
Rail Centerline (R)	37" [940]

*** PLEASE CALL FOR DIFFERENT DOOR OPENING CONFIGURATION AS HOISTWAY DIMENSIONS WILL BE AFFECTED.**



TYPE D

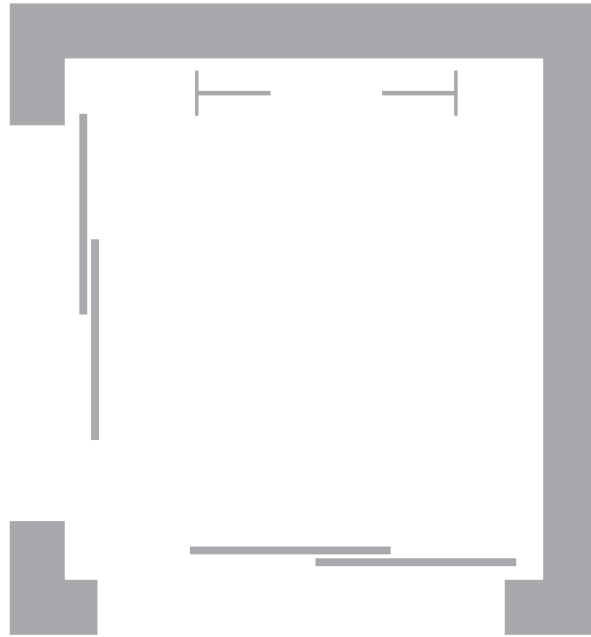

TWO POINTS OF ENTRY ON ALL LEVELS

Entrance options:



**2-Speed
Stainless Steel**



**2-Speed
Primed Steel**
Ready to be painted by others
(standard feature)



3-Speed
* Please contact us directly for
dimensions with this door option



TYPE D 2-SPEED DOOR

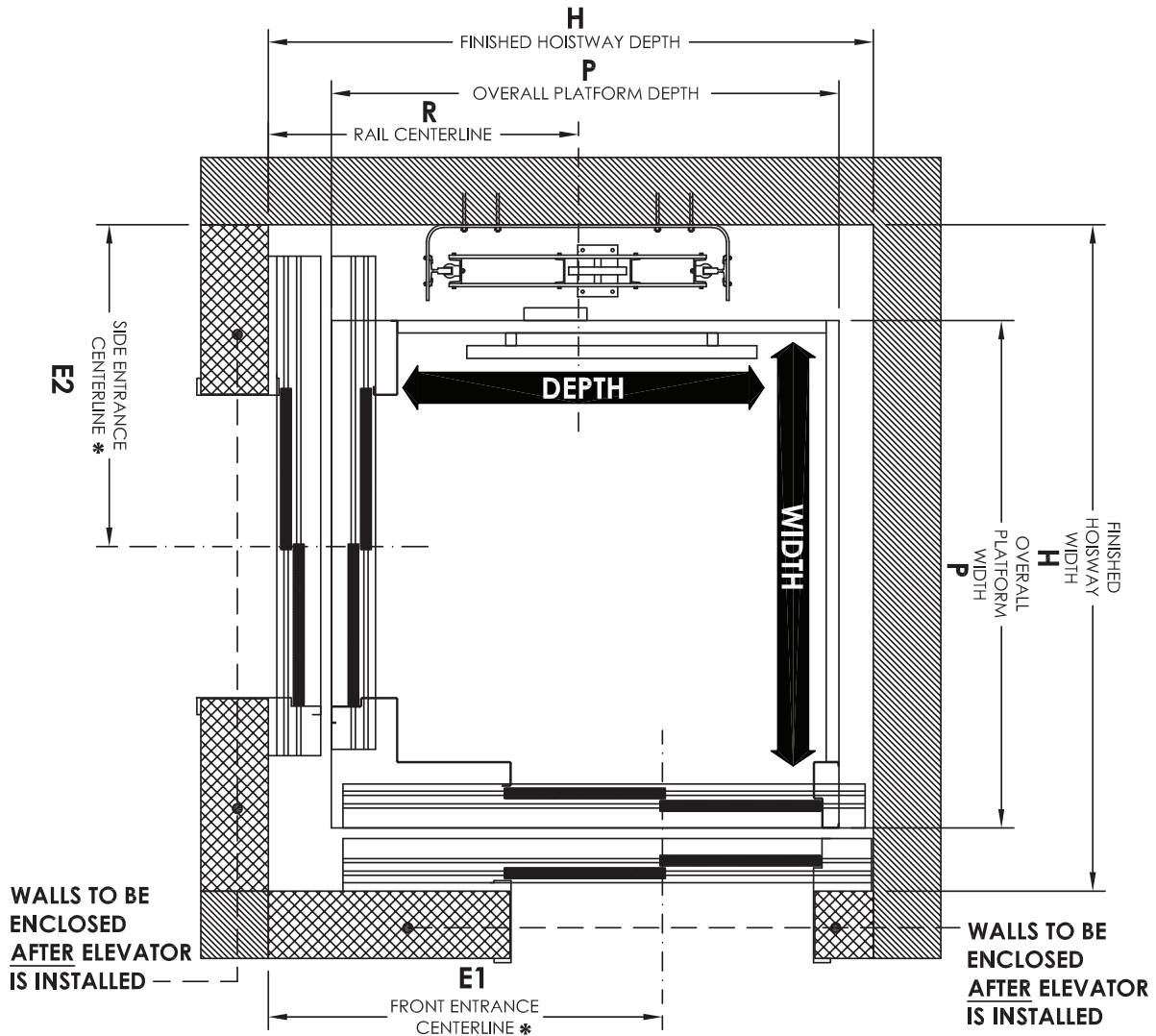

*** ENTRANCE CENTRELINE NOTES:**

- FEDERAL ELEVATOR DOES NOT ACCEPT RESPONSIBILITY FOR THESE DIMENSIONS AS THEY WILL VARY DEPENDING ON HOW PLUMB AND STRAIGHT THE HOISTWAY HAS BEEN CONSTRUCTED.
- BARRICADES SHALL BE PROVIDED OUTSIDE EVERY OPENING TO HOISTWAY WHILE ELEVATOR IS BEING INSTALLED. BARRICADES SHALL BE ERECTED, MAINTAINED AND REMOVED BY OTHERS WHEN INSTALLATION WORK IS COMPLETE. THIS IS FOR SAFETY OF OTHER TRADES AND BUILDING OCCUPANTS.
- WALLS TO BE ENCLOSED AFTER ELEVATOR IS INSTALLED.

Cab Size (Width X Depth)	51" x 51" 1295mm x 1295mm
Finished Hoistway (H) Width x Depth	83" x 72" [2108 x 1829]
Overall Platform (P) Width x Depth	60 3/8" x 60 3/8" [1534 x 1534]
Entrance Centerline * (E)	E1: 46 7/8" [1191] E2: 41 1/4" [1073]
Rail Centerline (R)	37" [940]

*** PLEASE CALL FOR DIFFERENT DOOR OPENING CONFIGURATION AS HOISTWAY DIMENSIONS WILL BE AFFECTED.**

DESIGN | ENGINEER | MANUFACTURE | INSTALL



Federal Elevator
1090 Lorimar Drive
Mississauga, ON L5S 2A1

Tel 905.458.4015
1.888.785.5438



www.federalelevator.com